

APPLICATIONS

FORD

Edge 2007-2009 / Expedition 2007-2009
Explorer 2006-2009 / Explorer Sport Trac 2006-2009
F-150 2004-2008 / F Series 2005-2008
Five-Hundred 2005-2007 / Focus 2005-2007 / FreeStar 2004-2007
Freestyle 2005-2007 / Fusion 2006-2009
Mustang 2005-2009 / Super Duty 2008-2009
Taurus 2008-2009 / Taurus X 2008-2009

MERCURY

Monterey 2004-2007 / Milan 2006-2008
Montego 2005-2007 / Mountaineer 2006-2009

Sable 2008-2009

LINCOLN

Mark LT 2005-2009

Factory Navigation Only: MKX 2007-2009 / Navigator 2007-2009

CT23FD06

KIT FEATURES

- Double DIN Radio Provision
- Stacked ISO Units Provision



KIT COMPONENTS

- A) Radio Housing (Double DIN and Stacked ISO DIN) • B) Double DIN Brackets • C) Spacers
• D) (4) Screws

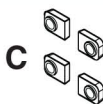
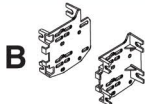
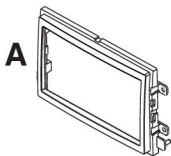

TOOLS REQUIRED:

- Cutting Tool • Panel Removal Tool • Phillips Screwdriver
• Socket Set



TABLE OF CONTENTS

Dash Disassembly

<i>Ford Edge 2007-2009</i>	1
<i>Ford F-150 2004-2008 / Expedition 2007-2009</i>	1
<i>Lincoln Mark LT 2005-2009</i>	1
<i>Ford Mustang 2005-2009</i>	2
<i>Ford Five Hundred 2005-2007</i>	3
<i>Mercury Sable 2008-2009</i>	3
<i>Ford Taurus 2008-2009</i>	3
<i>Mercury Montego 2005-2007</i>	3
<i>Ford Fusion 2006-2009</i>	4
<i>Mercury Milan 2006-2008</i>	4
<i>Ford Freestyle 2005-2007</i>	5
<i>Ford Taurus X 2008-2009</i>	5
<i>Ford Freestar 2004-2007</i>	6
<i>Mercury Monterey 2004-2007</i>	6
<i>Ford Focus 2005-2007</i>	7
<i>Ford Explorer 2006-2009</i>	8
<i>Ford Explorer Sport Trac 2006-2009</i>	8
<i>Mercury Mountaineer 2006-2009</i>	8
<i>Ford F Series Super Duty 2005-2008</i>	9
<i>Ford Super Duty 2009</i>	10
<i>Lincoln MKX 2007-2009</i>	11
<i>Lincoln Navigator 2007-2009</i>	12
<i>Kit Assembly</i>	
<i>Double DIN Radio Provision</i>	13
<i>Stacked ISO Units Provision</i>	14
<i>Final Assembly</i>	15

****Note: Refer also to the instructions included with the aftermarket radio.***

FORD F-150 2004-2008
LINCOLN MARK LT 2005-2009
FORD EXPEDITION 2007-2009
FORD EDGE 2007-2009

- 1** Disconnect the negative battery terminal to prevent an accidental short circuit.
- 2** Unsnap and remove entire panel surrounding the radio and climate controls. (Figure A)
- 3** Remove (4) 9/32" screws to remove the factory radio. (Figure B)

Continue to kit assembly.

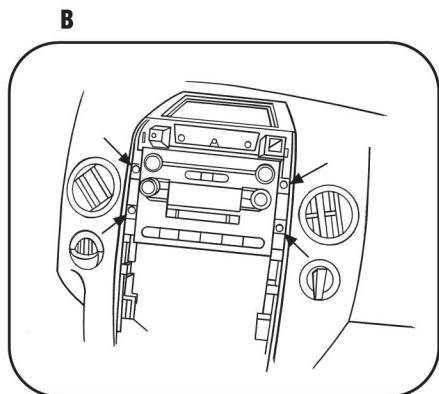
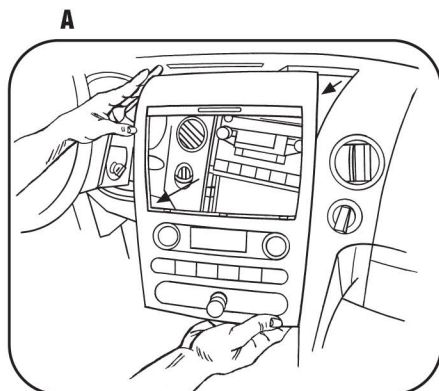

FORD MUSTANG 2005-2009

**Note: Refer also to the instructions included with the aftermarket radio.*

- 1 Disconnect the negative battery terminal to prevent an accidental short circuit.
- 2 Remove the small rectangular shifter lever trim panel if equipped. (Figure A)
- 3 Remove (2) Phillips screws from under the center armrest at the back of the shifter trim panel (including cup holders). (Figure B)
- 4 Unclip and remove panel. (Figure B)
- 5 Unclip and remove the (2) center stack trim panels from the left and right side of the radio and climate controls. (Figure C)
- 6 Remove (6) 9/32" screws from center trim panel surrounding the radio and climate controls then unclip and remove panel. (Figure D)
- 7 Remove (4) 9/32" screws from the radio to remove. (Figure E)

Continue to final assembly.

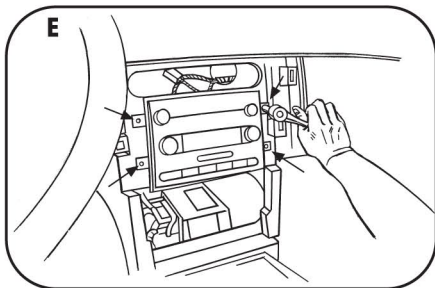
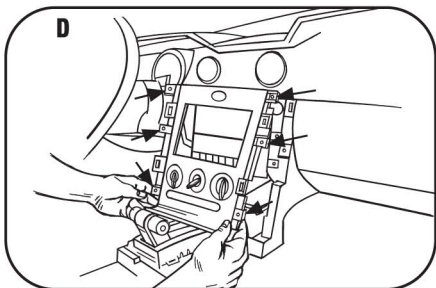
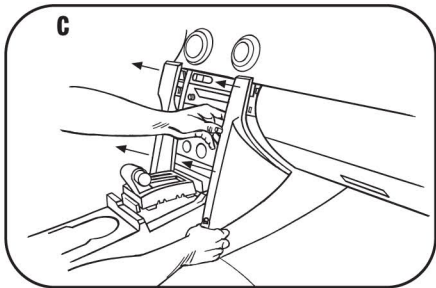
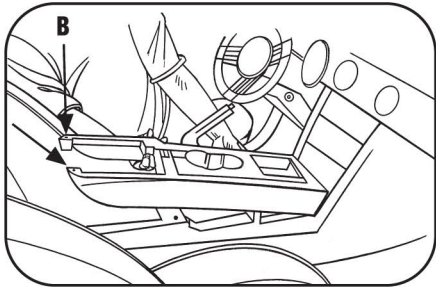
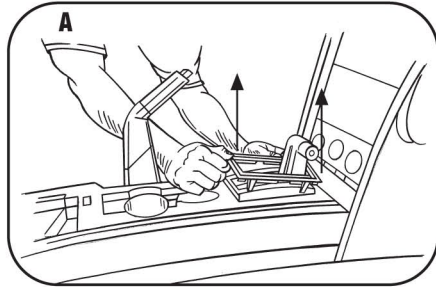

**FORD FIVE-HUNDRED 2005-2007/FORD TAURUS 2008-09
MERCURY MONTEGO 2005-2007, MERCURY SABLE 2008-09**

**Note: Refer also to the instructions included with the aftermarket radio.*

- 1 Disconnect the negative battery terminal to prevent an accidental short circuit.
- 2 Unclip and remove the small rectangular trim around shift lever. (Figure A)
- 3 Unclip and remove the entire panel (including cup holders) surrounding the shift lever. (Figure B)
- 4 Remove (2) 9/32" screws at the bottom of the center radio/climate control panel. (Figure C)
- 5 Unclip and remove the center panel. (Figure D)
- 6 Remove (4) 9/32" screws from the radio to remove. (Figure E)

Continue to final assembly.

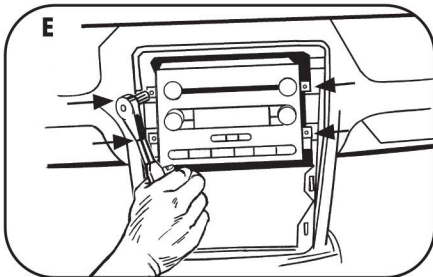
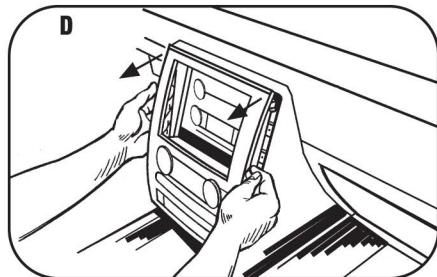
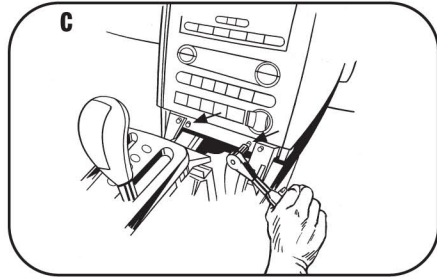
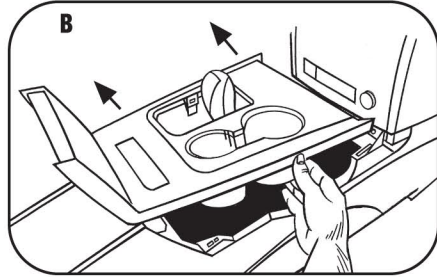
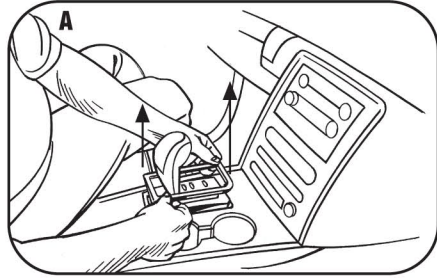

FORD FUSION 2006-2009 **MERCURY MILAN 2006-2008**

- 1** Disconnect the negative battery terminal to prevent an accidental short circuit.
- 2** Unsnap and remove entire panel surrounding the radio and climate controls. (Figure A)
- 3** Remove (4) 9/32" screws to remove the factory radio. (Figure B)

Continue to kit assembly.

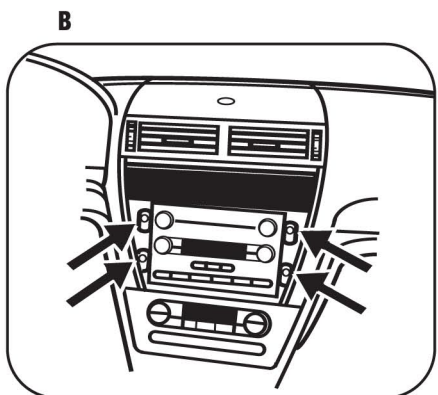
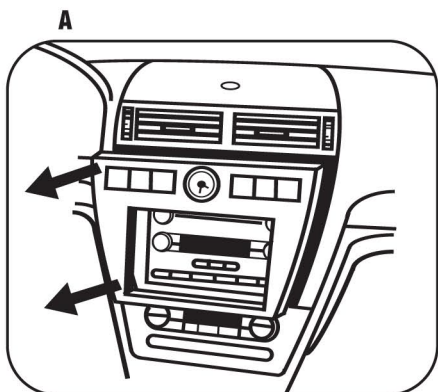

FORD FREESTYLE 2005-2007
FORD TAURUS X 2008-2009

- 1** Disconnect the negative battery terminal to prevent an accidental short circuit.
- 2** Unclip and remove entire panel surrounding the radio and a/c controls. (Figure A)
- 3** Remove (4) 9/32" screws from radio to remove. (Figure B)

Continue to kit assembly.

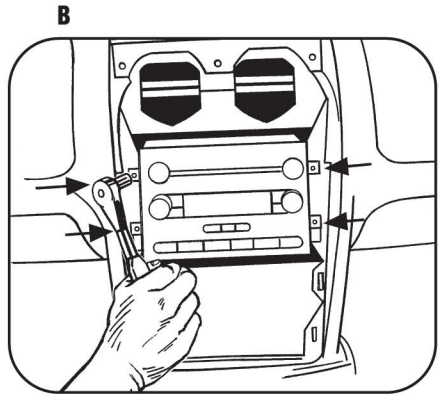
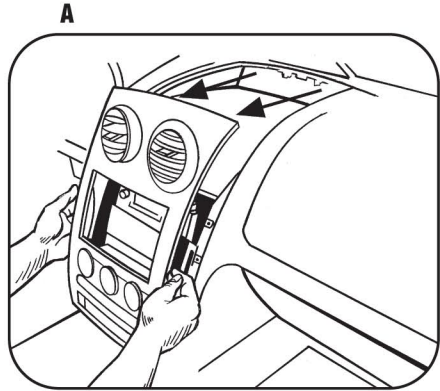

FORD FREESTAR 2004-2007
MERCURY MONTEREY 2004-2007

- 1** Disconnect the negative battery terminal to prevent an accidental short circuit.
- 2** Unsnap and remove entire panel surrounding the radio and climate controls. (Figure A)
- 3** Remove (4) 9/32" screws to remove the factory radio. (Figure B)

Continue to kit assembly.

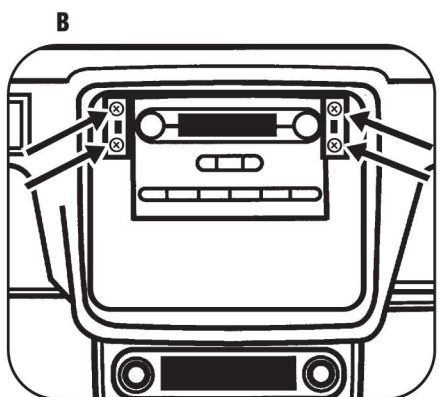
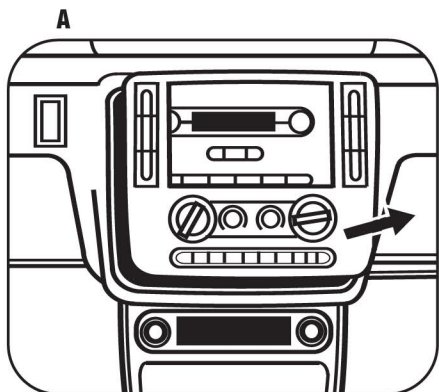

FORD FOCUS 2005-2007

- 1** Disconnect the negative battery terminal to prevent an accidental short circuit.
- 2** Unsnap and remove entire panel surrounding the radio and climate controls. (Figure A)
- 3** Remove (4) 9/32" screws to remove the factory radio. (Figure B)

Continue to kit assembly.

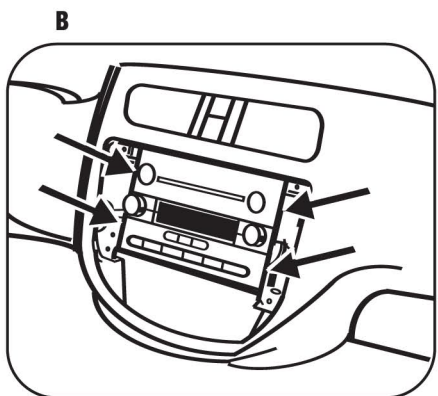
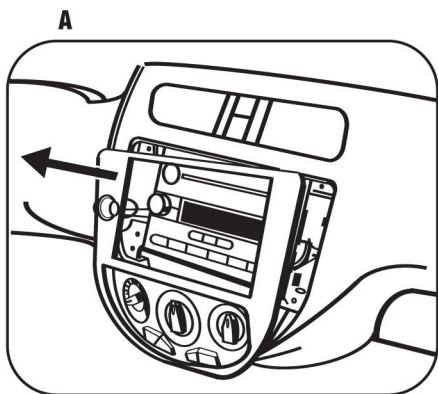

FORD EXPLORER/EXPLORER SPORT TRAC 2006-2009
MERCURY MOUNTAINEER 2006-2009

- 1 Disconnect the negative battery terminal to prevent an accidental short circuit.
- 2 Open center console and remove (2) Phillips screws then unclip and remove entire panel surrounding shifter. (Figure A)

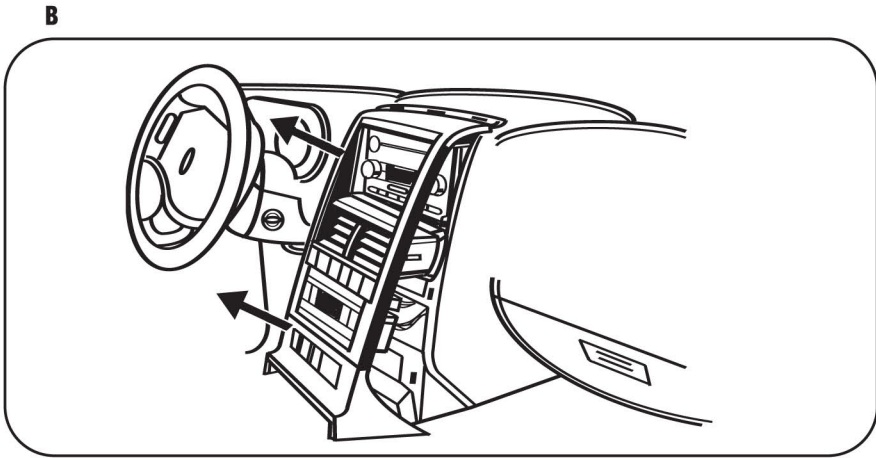
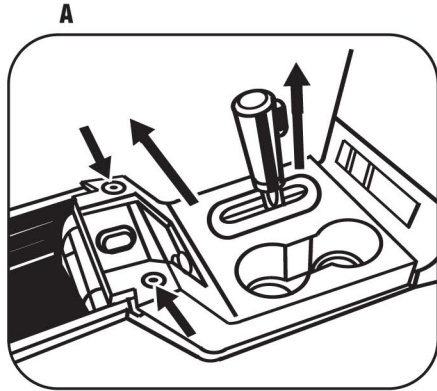

- 3 Remove dash panel surrounding radio to access the factory radio screws. (Figure B)
- 4 Remove (4) 9/32" screws to remove the factory radio. (Figure B)

Continue to kit assembly.

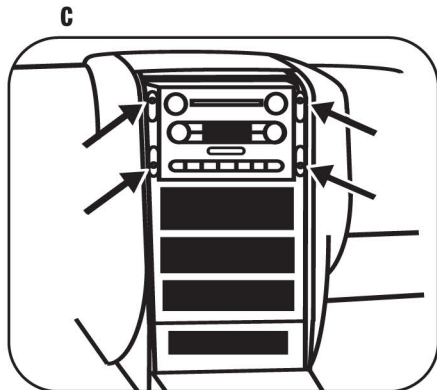

FORD F SERIES SUPER DUTY 2005-2008

- 1** Disconnect the negative battery terminal to prevent an accidental short circuit.
- 2** Unsnap and remove entire panel surrounding the radio and climate controls. (Figure A)

A

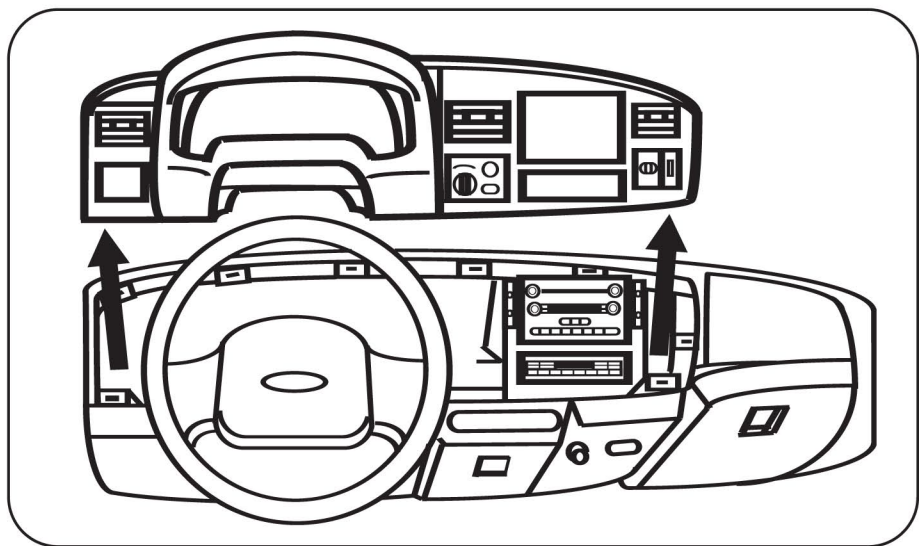

- 3** Remove (4) 9/32" screws to remove the factory radio. (Figure B)

Continue to kit assembly.

B

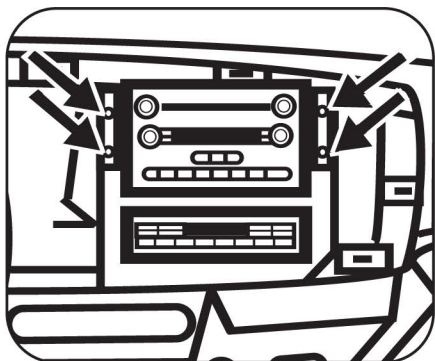

FORD SUPER DUTY 2008-2009

- 1** Disconnect the negative battery terminal to prevent an accidental short circuit.
- 2** Unclip and remove the power outlet panel and the blank panel on the left and right side of the radio trim panel.
(Figure A)

A

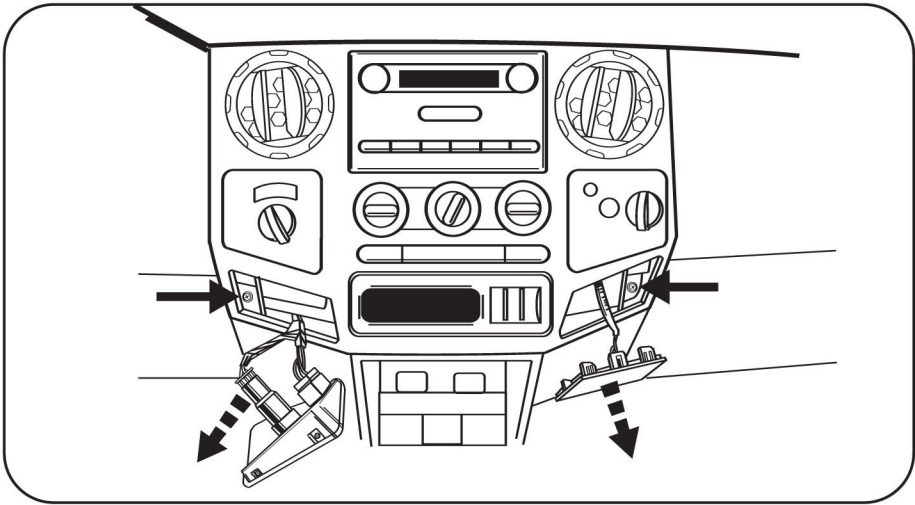

- 3** Remove the (2) 9/32" screws exposed behind the two panels remove in step 2.
- 4** Unclip and remove the entire radio trim panel including the a/c control and vents.
- 5** Remove (4) 9/32" screws securing the radio.

Continue to kit assembly

LINCOLN MKX 2007-2009

- 1** Disconnect the negative battery terminal to prevent an accidental short circuit.
- 2** Open center console lid and unclip and remove the center console trim panel surrounding the shifter. (Figure A)
- 3** Remove (2) Phillips screws from the storage bin then unclip and remove the bin. (Figure B)
- 4** Unclip and remove the upper and lower center trim panel as one assembly. (Figure C)
- 5** Remove (4) 9/32" screws securing the radio. Unplug and remove the Radio.

Continue to kit assembly.

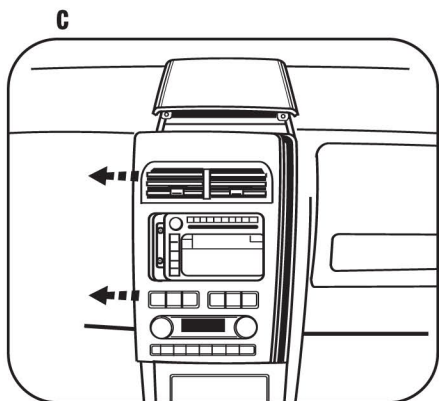
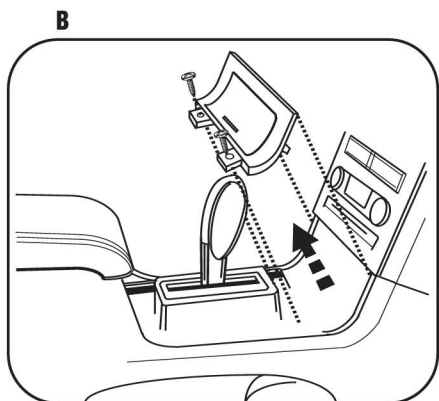
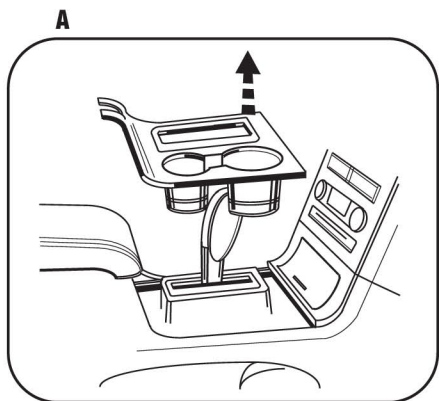

LINCOLN NAVIGATOR 2007-2009

- 1** Disconnect the negative battery terminal to prevent an accidental short circuit.
- 2** Unclip and remove the panel surrounding the shifter. (Figure A)
- 3** Remove (2) 9/32" screws from the bottom of the radio/climate control trim panel. (Figure B)
- 4** Unclip and remove the entire panel surrounding the radio and including the climate controls. (Figure B)
- 5** Remove (4) 9/32" screws securing the radio. Unplug and remove the Radio.

Continue to kit assembly.

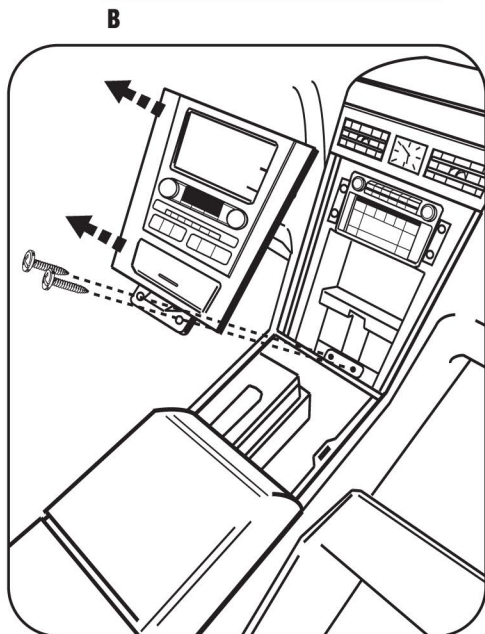
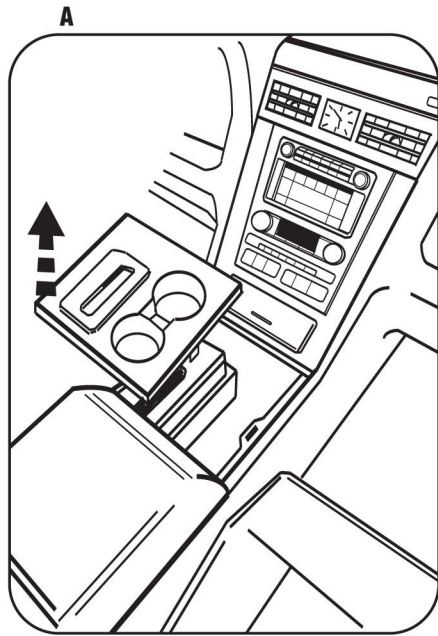

DOUBLE DIN RADIO PROVISION

**Note: Refer also to the instructions included with the aftermarket radio.*

- 1 For the **2007 Ford Edge/Expedition, 2006-07 Explorer/Fusion/Mercury Milan, 2004-07 F-150, 2005-07 Five Hundred/Freestyle/Mustang/Mercury Montego, 2005-07 Lincoln Mark LT** and the **2008 Super Duty**, cut and remove the rear mounting tabs from the Double DIN Brackets.
a. If your vehicle is not listed above move to step 2.

- 2 For the **2007 Ford Edge/Expedition, 2006-07 Explorer, 2006-07 Fusion, 2007 Mustang** and the **2008 Super Duty** attach the included spacers to the back of the radio housing mounting tabs.
a. If your vehicle is not listed above move to step 3. (Figure A)

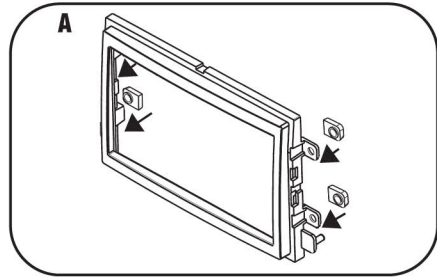

- 3 Attach the double DIN brackets to the radio housing. **Note:** The notch in the housing should be on top. (Figure 3A,3B)

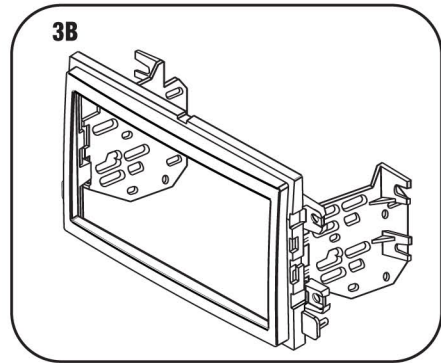
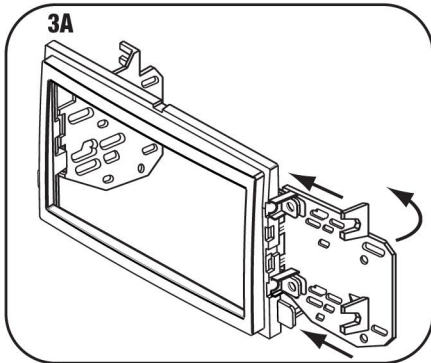

- 4 Slide the Double DIN radio into the radio housing/bracket assembly and secure the radio to the assembly using the screws supplied with the radio. (Figure C)

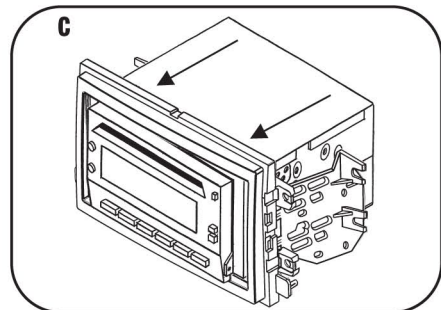

Continue to kit assembly.

STACKED ISO UNITS PROVISION

**Note: Refer also to the instructions included with the aftermarket radio.*

- 1** For the **2007 Ford Edge/Expedition, 2006-07 Explorer/Fusion/Mercury Milan, 2004-07 F-150, 2005-07 Five Hundred/Freestyle/Mustang/Mercury Montego, 2005-07 Lincoln Mark LT** and the **2008 Ford Super Duty**, cut and remove the rear mounting tabs from the Double DIN Brackets.

a. If your vehicle is not listed above move to step 2.

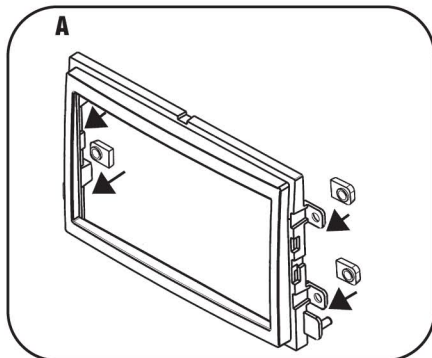

- 2** For the **2007 Ford Edge/Expedition, 2006-07 Ford Explorer, 2006-07 Ford Fusion, 2007 Mustang** and the **2008 Super Duty** attach the included spacers to the back of the radio housing mounting tabs.

(Figure A)

a. If your vehicle is not listed above move to step 3.

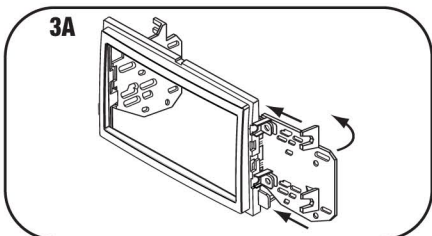

- 3** Attach the double DIN brackets to the radio housing. **Note:** The notch in the housing should be on top. (Figure 3A,3B)

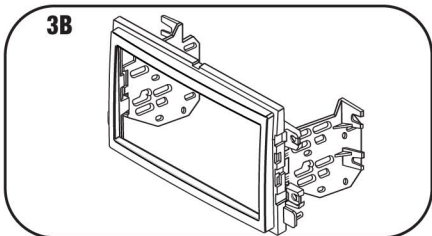

- 4** Slide the ISO mount units into the radio housing/bracket assembly and secure the units to the assembly using the screws supplied with the units. (Figure C)

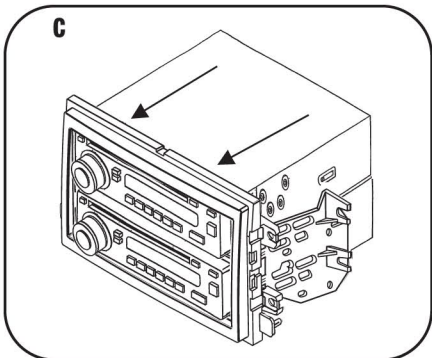

Continue to kit assembly.